

PLAN

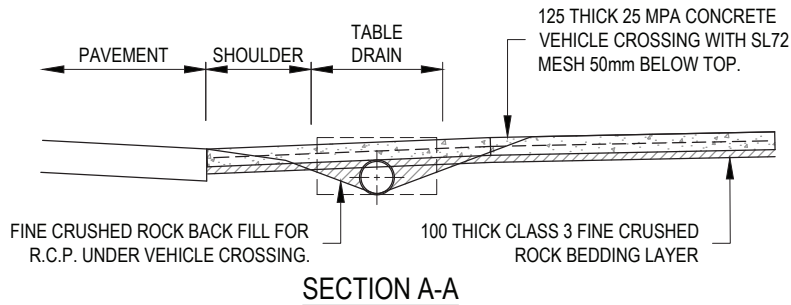

NOTES:

1. COUNCIL RESERVES THE RIGHT TO DIRECT THE USE OF CULVERT END WALL TYPE.
2. THIS IS A TYPICAL CROSSING PLAN. SLIGHT VARIATIONS MAY OCCUR AFTER INSPECTION AND APPROVAL OF LOCATION BY COUNCIL.
3. PRIOR TO THE CONSTRUCTION, THE CROSSING LOCATION SHALL BE APPROVED BY COUNCIL.
4. ALL WORKS TO BE COMPLETED TO THE SATISFACTION OF COUNCIL.
5. MAINTENANCE OF THE CROSSOVER REMAINS THE RESPONSIBILITY OF THE LAND OWNER.
6. DRIVEABLE ENDWALLS TO BE USED WITHIN 1.5m OF THE EDGE OF SEAL OR IF DESIGN SPEED IS GREATER THAN 60KM/H
7. REFER SD255 FOR ADDITIONAL CLEAR ZONE DETAILS
8. TABLE DRAINS ARE NOT TO BE CLOSER THAN 1.0m FROM FENCE LINES OR SERVICES.
9. CULVERT TO BE LOCATED AT LEAST 600mm FROM EDGE OF SEAL
10. MAXIMUM DRIVEWAY WIDTH MAYBE INCREASED UPON COUNCIL APPROVAL

ALL MEASUREMENTS IN MILLIMETRES

**TYPICAL SWALE DRAIN VEHICLE CROSSING
(FRINGE URBAN OR RURAL RESIDENTIAL ENTRANCE)**

LAST UPDATED 12/03/2020

SD 260

Infrastructure Design Manual Standard Drawings

A copy of the Infrastructure Design Manual can be viewed on the Design Manual website www.designmanual.com.au

NOT TO SCALE