

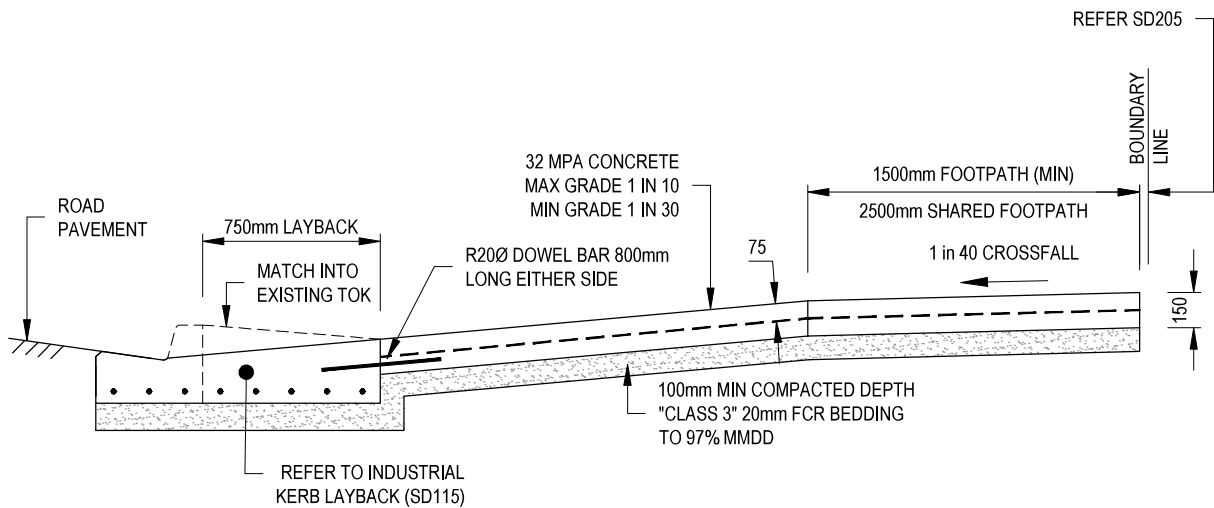

PLAN



SECTION A-A

LEGEND:

- EXPANSION JOINT 
- WEAKENED PLANE JOINTS 

NOTE:

1. T.O.K. DENOTES TOP OF KERB
2. WHERE THERE ARE EXPANSIVE SOILS AN ADDITIONAL LAYER OF REINFORCEMENT MAY BE REQUIRED AT 60mm COVER FROM THE BOTTOM OF THE SLAB.
3. FOR STEEP TERRAIN CONTACT THE COUNCIL FOR GUIDANCE.
4. FOR GRADES STEEPER THAN 1 IN 10 REFER TO CLAUSE 12.9.1.4.
5. REFER SD236 FOR DETAILS TO RETROFIT INDUSTRIAL VEHICLE CROSSING INTO EXISTING.

ALL MEASUREMENTS IN MILLIMETRES

NEW INDUSTRIAL VEHICLE CROSSING DETAIL

LAST UPDATED 26/02/2020

Infrastructure Design Manual Standard Drawings

A copy of the Infrastructure Design Manual can be viewed on the Design Manual website www.designmanual.com.au

SD 250

 Local Government
Infrastructure Design Association

NOT TO SCALE